

Discovering  
Mobilvetta  
**2022**





## HIGHLIGHTS



### *Luxury experience*

LUXURY AND ELEGANCE  
AESTHETICAL AND FUNCTIONAL EXCLUSIVITY  
PREMIUM CLASS COMFORT



### *Italian Style and Design*

UNIQUE INTERIOR DESIGN  
DISTINCTIVE EXTERIORS  
HIGH-END MATERIALS  
CARE FOR DETAILS  
HISTORICAL ITALIAN STYLE.



### *Technology and Technique*

ADVANCED CONSTRUCTION TECHNIQUES.  
TECHNOLOGICAL INNOVATION



### *Energy and Autonomy*

IMPROVED TRAVEL AUTONOMY WITH NEW  
SOLUTIONS  
KNOW-HOW AND CONTINUOUS RESEARCH



# Guidelines



- Distinctive Made in Italy design and style;
- Technical innovation, high performance;  
Energy and Autonomy;  
Premium class comfort.

## Mobilvetta 2022

EXPANDS THE OFFER OF *top class motorhome* with a new range on an AL-KO chassis.

PROPOSES NEW *exclusive technical solutions* Crosswise to all ranges for improved autonomy, energy storage, onboard connectivity and living comfort.

INTRODUCTION OF a PREMIUM *van product range* To complete Mobilvetta offer with 3 layouts

*compact layout available*

2 new layouts, one of which under 7 meters Available on Kea and Krosser ranges.

2021

A-CLASS



KEA I



K-YACHT  
TEKNO LINE



K-YACHT  
TEKNO DESIGN

HALF-INTEGRATED



KEA P



KROSSER

OVERCAB



KEA M

# GUIDELINES 2022

2022



A-CLASS



KEA I



K-YACHT  
TEKNO LINE

HALF-INTEGRATED



KEA P

KROSSER



VAN



ADMIRAL

K-YACHT TEKNO DESIGN  
KEA M



# RANGE PLAN 2022

> 5 METRES ●●●

> 6 METRES ●●●●●● > 7 METRES

< 7.5 METRES ●●●



K-YACHT  
TEKNO LINE

KEA I

	 KEA i67	 KEA i64	 KEA i71 IN DESIGN	 KEA i86	 KEA i90
		 K-YACHT TEKNO LINE 64		 K-YACHT TEKNO LINE 86	 K-YACHT TEKNO LINE 90

KROSSER

KEA P

	 KEA P67	 KEA P64	 KEA P71 IN DESIGN	 KEA P86	 KEA P90
		 KROSSER 64	 KROSSER 70	 KROSSER 86	 KROSSER 90



ADMIRAL

 K 5.1	 K 6.3	 K 6.5			
-----------	-----------	-----------	--	--	--

A-CLASS

HALF-INTEGRATED

VAN

# EVOLUTION IN ALL PRODUCT LINES

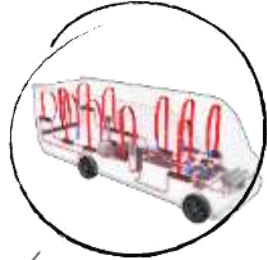

Alde  
HEATER



Variable  
BATHROOM SPACE



Insulated  
INTEGRATED STEP



Oversized  
TANKS



Facilities  
AND UTILITIES

K-YACHT  
TEKNO LINE



Model 64



KROSSER



Model 64



KEA



Model 64



OPTIONAL



OPTIONAL

## **Alde** HEATER

The Alde central heating system is a heat transfer fluid system, based on similar principles that characterise domestic heating systems.

It works through a gas boiler that heats the liquid contained in the system. Once heated, a pump circulates the liquid in a circuit of interconnected radiators.

The heated air spreads evenly throughout the interior of the motorhome. The system heats the air that circulates inside through slits placed on the wall units; once cooled it goes down and passing through the furniture raised from the ground can heat up again and return hot in circulation.

### *The benefits:*

- +** Healthy atmosphere.  
Atmosphere free from suspended dust and feeling of dryness.
- +** Even and longer-lasting warmth.
- +** Quiet operation.  
No ventilation.
- +** Continuous production of hot water.





# Alde<sup>®</sup> HEATER

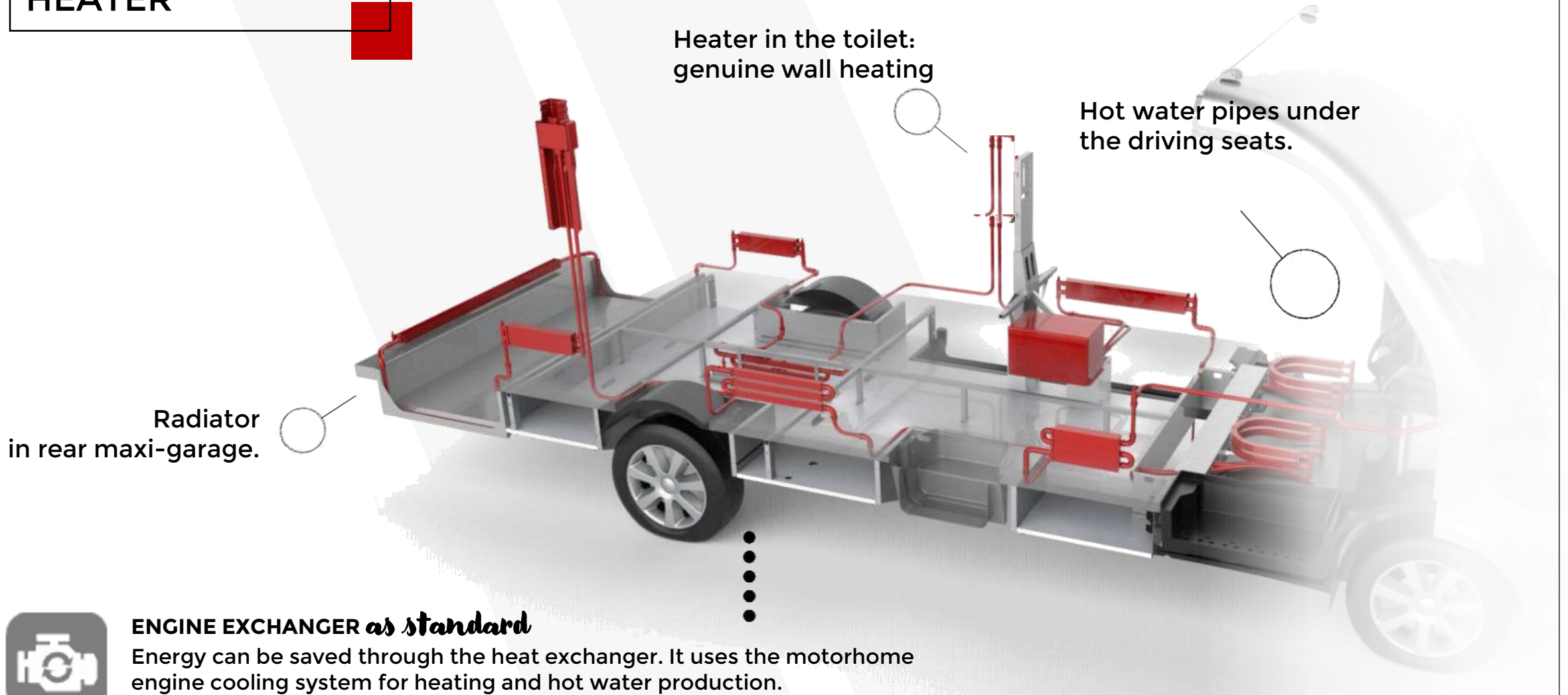

Radiator  
in rear maxi-garage.

Heater in the toilet:  
genuine wall heating

Hot water pipes under  
the driving seats.



## **ENGINE EXCHANGER** *as standard*

Energy can be saved through the heat exchanger. It uses the motorhome engine cooling system for heating and hot water production.

OPTIONAL EQUIPMENT. AVAILABLE FOR K-YACHT TEKNO LINE AND KEA.

# AVAILABILITY



**K-YACHT  
TEKNO LINE**

**KEA**

Deliveries  
February/March 2022

Deliveries  
February/March 2022

OPT. RESIDUAL LOAD: 40 KG  
WITH ALDE 3 SEATS

OPT. RESIDUAL LOAD: 80 KG  
WITH ALDE 4 SEATS

**KROSSER** Possible development 2023

## VARIABLE VOLUME TOILET



A variable volume bathroom to make the most of the space available in models under 7 metres.

Modular spaces for:

- ⊕ Toilet: more space to move around, in width and depth.
- ⊕ Shower: plenty of free space.

*Available on:*

K-YACHT TEKNO LINE 64

KROSSER 64

KEA P64

KEA I64







## INTEGRATED AND INSULATED STEP



**Comfortable boarding.**  
Double step,  
rectangular shape,  
deep tread.

## OVERSIZED TANKS

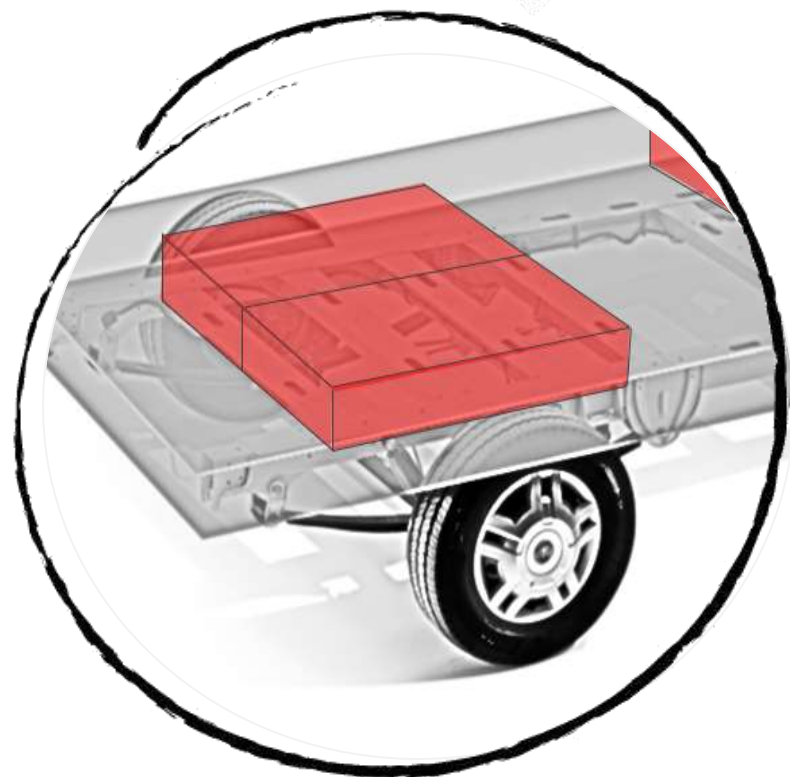

**+** Higher capacity.  
Greater autonomy.

		FRESH WATERS	GREY WATERS
K-YACHT TEKNO LINE	FACE-TO-FACE	145	135
	L-SHAPED DINETTE	145	135
KROSSER	FACE-TO-FACE	145	135
	L-SHAPED DINETTE	145	135
KEA	FACE-TO-FACE	120	100
	L-SHAPED DINETTE	-	-



Capacity  
in line with  
the main  
competitors.



Higher capacity  
than major  
competitors.

## LIVING THE MOTORHOME, OUTSIDE THE MOTORHOME!

Gas connection  
Water connection,  
Electrical socket,  
TV antenna socket.



### **COOKING OUTSIDE.** **Gas connection.**

The gas outlet allows you to connect a barbecue or an outdoor camping kitchen.



### **LEAVE THE DIRT OUTSIDE.** **Water connection.**

Positioned in the rear maxi-garage allows you to freshen up outdoors or rinse accessories before stowing them in the maxi-garage or motorhome.



### **OUTDOOR ENTERTAINMENT.** **TV antenna socket.**

To feel good, alone, with friends, outdoors, in the enclosure, for a holiday immersion.



### **PRACTICAL PURPOSE.** **220 V + 12 V electrical socket.**

Always available for any DIY activity outside the motorhome as well.



# K-Yacht Tekno Line

## THE MOST ICONIC MOBILVETTA MODEL

Mobilvetta Design;  
Exclusive style, Made in Italy;  
High-quality materials;  
Integrated skyroof  
Improved lighting;

AL-KO chassis: Double floor and great driveability

Furniture with anti-condensation system;

Efficient air distribution;  
Modular bathroom,  
Rich equipment.

Tanks between floor layers  
Oversized tanks;  
Lithium-ready,  
Compressor refrigerator  
Possibility of Wi-Fi connection;  
Room for 32" Smart TV;  
Audio diffusion in day and night area  
External utilities: water, TV, electric power and gas;  
Alde heater as a option





MOBILVETTA

**EXTERIORS.**

## EXTERIORS AND SYSTEMS.

Beauty of shapes,  
balance between elegance and sportiness,  
the beauty of travelling.

**CURVED WALL-ROOF  
JOINT**

**INTEGRATED SKYDOME STD**  
Dimensions 100x80 cm

USP

**CURVED  
WINDSCREEN**

**FULL LED HEADLIGHTS  
WITH DYNAMIC  
DIRECTION INDICATORS**

**On request,  
FULL LED  
HEADLIGHTS**  
Optional equipment

**CHASSIS AL-KO**

**XXL TANKS**





# AL-KO CHASSIS





# CHASSIS **AL-KO**: how it is made

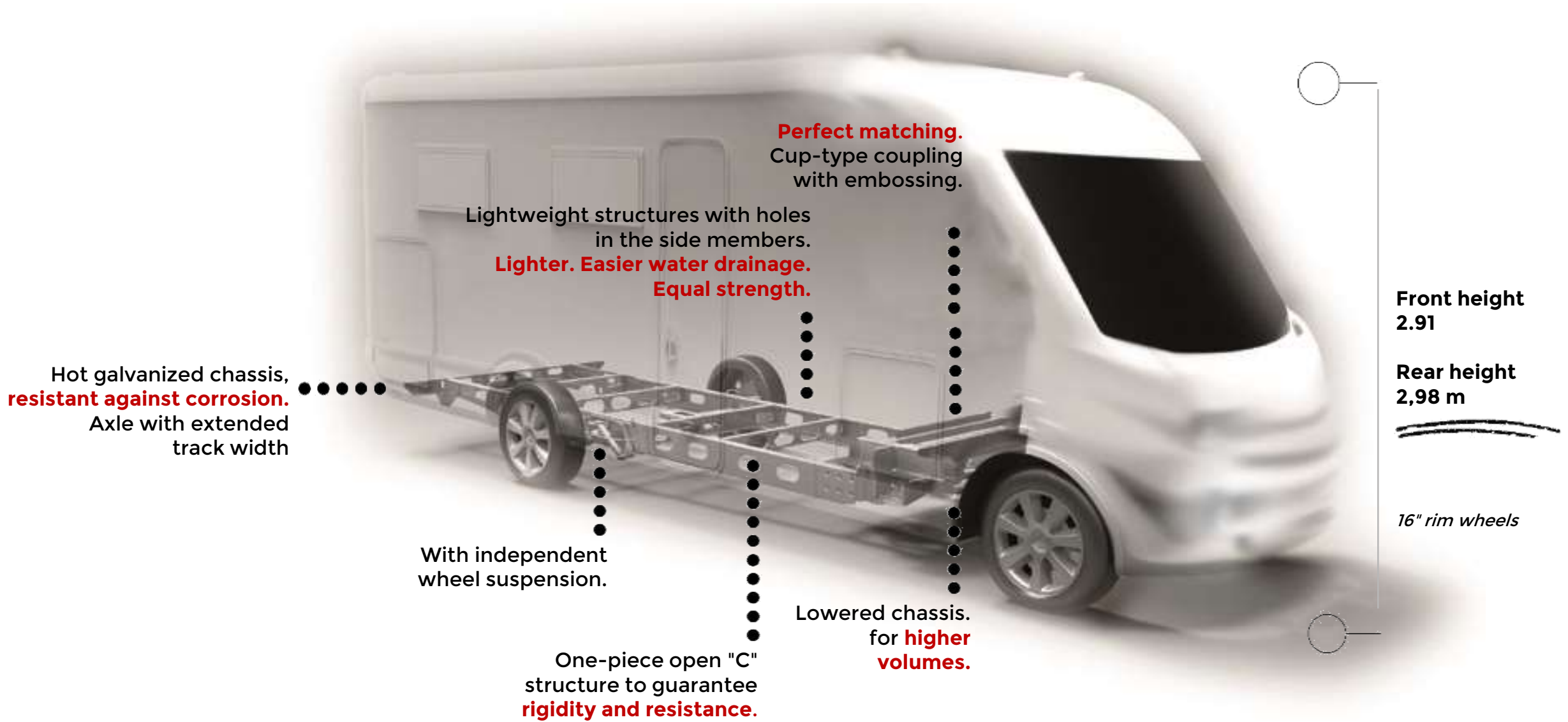

Hot galvanized chassis,  
**resistant against corrosion.**  
Axle with extended  
track width

With independent  
wheel suspension.

One-piece open "C"  
structure to guarantee  
**rigidity and resistance.**

Lightweight structures with holes  
in the side members.  
**Lighter. Easier water drainage.**  
**Equal strength.**

**Perfect matching.**  
Cup-type coupling  
with embossing.

Lowered chassis.  
for **higher**  
**volumes.**

Front height  
2.91

Rear height  
2,98 m

*16" rim wheels*

*Design, Distinction, Technique*



## DOUBLE FLOORING.

THE PRIVILEGE OF HIGH PERFORMANCE IN TERMS OF SPACE, VOLUMES, INSULATION.

The AL-KO lowered chassis is ideal for creating a double flooring for lots of stowage space and for the use of rear garages and following loading.

But not only that!

It increases the space inside with advantages also in terms of living space.



### **Through maxi-garage**

which exploits the space created between the two floors. Internal height: 19 cm.



### **Additional stowage space, easily accessible**

The storage space is accessible from inside the motorhome, via specific hinged maxi hatches, and from outside via opening hatches on both sides of the motorhome.



### **An extra-large maxi-garage .... always!**

The lowering of the chassis ensures a large maxi-garage on the outside and a bed on the inside that is easy to access, without the need for variable volume mechanisms.



### **Frost-protected tanks.**

The tanks are located between the two floors: in such a position they are protected from frost and better insulated from the outside.



# CHASSIS **AL-KO**: stowage volume



●●●●● Double flooring with  
19 cm clearance



Access to the double floor  
for storage on both sides of  
the vehicle thanks to large  
and practical doors

Maxi central hatch with hinged door. ●●●●●  
Space for shoes, bottles, boxes, tools.  
Capacity 93 litres (*Model 64*)  
84 litres (*Models 90 and 86*).





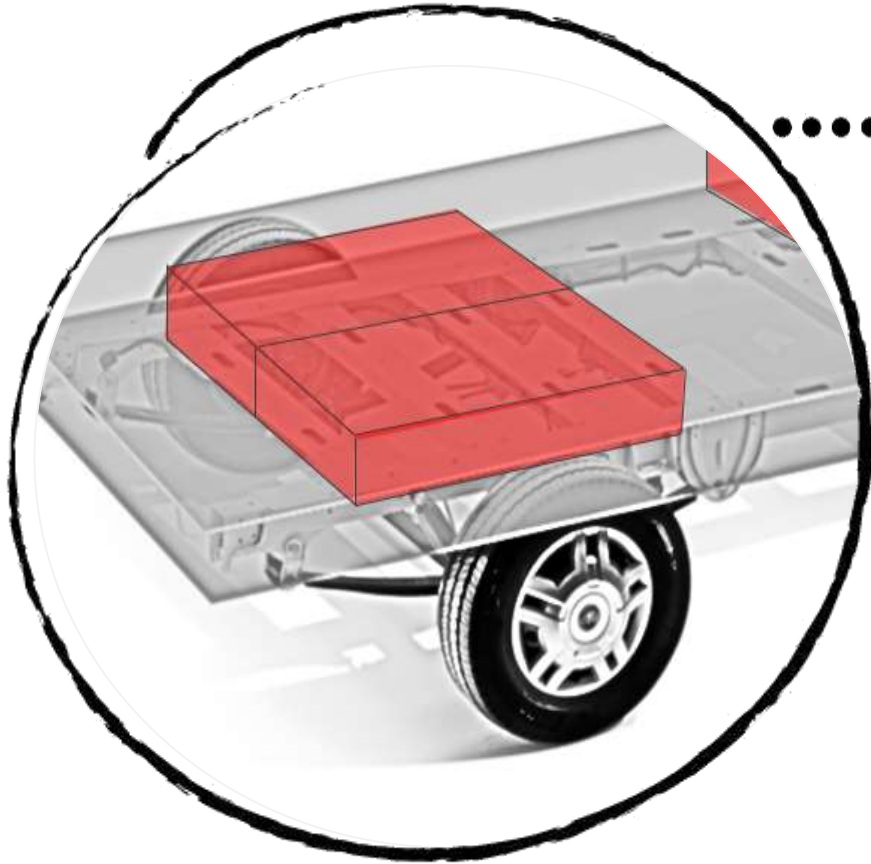

●●●●● Fresh water tank and grey water tank positioned in the double flooring: they are protected and insulated from the upper and lower floor.

**GREATER CAPACITY,  
GREATER AUTONOMY.**

**145 LITRES.**

Fresh water tank.

**135 LITRES.**

Waste water tank.



●  
●  
●  
●  
●  
●  
●  
●  
●  
●  
Access via hatches to the drain cocks and fresh water tank.



●●●●● **An extra-large maxi-garage .... always!**  
The lowered chassis allows for a maxi-sized garage.  
The rear room remains extremely liveable and the  
bed, of whatever type, remains easily accessible.

**Accessible bed, large garage:**  
Without variable volume systems,  
With clear separation between room and garage,  
No bad smells from the garage,  
A fully insulated and protected room!

○ internal height: 112 cm (Models 64 and 86)  
and 106 cm (Model 90).



## LITHIUM READY - READY FOR LITHIUM BATTERIES

*with battery charger included.*

### MORE CHOICE, MORE AUTONOMY.

In a motorhome it is important to have some spare electricity available during stops. In summer and more often in winter having good batteries will allow you to have a **good electric autonomy** to enjoy in perfect relax all the days of holidays also in free parking areas.



*System ready for integration with Teleco batteries.*

### + MORE ENERGY AND AUTONOMY ON BOARD.



Up to 90% of their capacity can be used, compared to 30% for AGM batteries. This means that with one lithium battery you can have more energy than with 2 AGM batteries.

### + GREATER DURABILITY.



They have a very low self-discharge current, i.e. the battery will still have a high charge when used after a medium to short-term storage period.

Lithium batteries last much longer than AGM batteries supporting 2000 to 5000 charge and discharge cycles. So they can last as long as the life of the motorhome.... always in perfect working order.

Lithium batteries are equipped with an overload and short circuit protection circuit, so they are safe for extended and efficient motorhome use.

### + LESS WEIGHT.



The weight of lithium batteries is about 2 times less than the weight of AGM batteries. Considering that a single lithium battery can replace two AGM batteries and still provide more electricity, the overall weight saving is remarkable.



## COMPRESSOR REFRIGERATOR READY

**MORE CHOICE,  
MORE AUTONOMY.**

**COMPRESSOR REFRIGERATOR OFFER,  
IMPROVED PERFORMANCE  
THANKS TO LITHIUM BATTERIES!**

Combined with the lithium battery, it is possible to order the compressor refrigerator.



*As a replacement.  
The outer grids are still there.  
System ready for integration  
with Teleco batteries.*

### **+ COOLER AND SOONER.**

- It reaches the temperature in a short time obtaining the desired coolness to preserve at best drinks and food of various kinds, in a much shorter time compared to the three-way fridge.

### **+ IS NOT AFFECTED BY HEAT.**

- It does not suffer from hot periods and is less affected by temperatures above average.

### **+ CHOOSE HOW TO USE IT.**

- It has separate functions to activate the refrigerator and freezer, turning the latter into a "cool" compartment if not activated.

### **+ SMART ENERGY CONSUMPTION.**

- Like on a domestic refrigerator, the compressor runs for a few minutes every 15-20 minutes. This results into a considerable energy saving: the system works only 10-20 minutes every hour and not 24 hours a day!

**EXTERIOR SPECIFICATIONS:**  
*THE BEST EQUIPMENT INCLUDED.*

# EXTERIORS AND SYSTEMS.

Make yourselves comfortable!  
Superbly equipped,  
for every need.

FIBERGLASS ROOF

ALUMINIUM  
WALLS

LED HEADLIGHTS WITH  
DYNAMIC DIRECTION  
INDICATORS

GAS CONNECTION  
WATER CONNECTION,  
ELECTRICAL SOCKET,  
TV ANTENNA SOCKET.

XL DOOR

ALUMINIUM  
BANDS

TRUMA COMBI 6 kW  
CP PLUS

MANUAL AIR CLIMATE CONTROL  
SYSTEM;  
PASSENGER AIRBAG;  
CRUISE CONTROL;  
ESC AND TRACTION +;  
STEERING WHEEL RADIO  
CONTROLS;  
DRL LED HEADLIGHTS;  
PLEATED BLIND;  
BUS-TYPE REAR-VIEW MIRRORS;

2.2 MULTIJET3  
140 HP

WHEELS WITH 16"  
ALLOY RIMS



## ALUMINIUM WALLS!



**+** **LIGHTWEIGHT.**

**+** **AESTHETICS.**  
Shiny, glossy walls.  
For a long time.

Elegance and stylishness.  
Identity and recognisability.

**+** **LONG LIFE.**  
Colour does not change over time.  
No deterioration.  
Easy to repair.  
Easy to maintain and clean.

WELCOME  
ON BOARD!



**XL door.**  
Useful clearance 60 cm.  
2-point door.  
Central locking.  
Integrated dustbin.  
Fixed window with blind.



**Comfortable boarding.**  
Double step,  
rectangular shape,  
deep tread.



LIVING THE  
MOTORHOME,  
OUTSIDE THE  
MOTORHOME!

GAS CONNECTION  
WATER CONNECTION,  
ELECTRICAL SOCKET,  
TV ANTENNA SOCKET.



**COOKING OUTSIDE.**  
**Gas connection.**



The gas outlet allows you to connect a barbecue or an outdoor camping kitchen.



**LEAVE THE DIRT OUTSIDE.**  
**Water connection.**



Positioned in the rear maxi-garage allows you to freshen up outdoors or rinse accessories before stowing them in the maxi-garage or motorhome.



**OUTDOOR ENTERTAINMENT.**  
**TV antenna socket.**



To feel good, alone, with friends, outdoors, in the enclosure, for a holiday immersion.



**PRACTICAL PURPOSE.**  
**220 V + 12 V electrical socket.**



Always available for any DIY activity outside the motorhome as well.

**INTERIORS.**

**WI-FI READY**



**SOFT TOUCH  
WALLS AND  
ROOF**



**BRIGHTNESS AND  
LIGHTING**



**ANTI-CONDENSATION  
FURNITURE**





## PREPARATION FOR WI-FI CONNECTION

ALWAYS CONNECTED



4 DEVICES CONNECTED  
AT THE SAME TIME

MORE POWERFUL  
RECEPTION THAN A  
SMARTPHONE  
HOTSPOT.

UNLIMITED  
AUTONOMY.  
12 V OPERATION

ALL DEVICES ALWAYS  
AVAILABLE.

*Optional equipment.*

RELAXATION, ENTERTAINMENT,  
INFORMATION, WORK.  
SAFELY AND FREELY.  
NOW YOU CAN:

- + **Safely surf in the internet, without public Wi-Fi,**
- + **Arrive smoothly at your destination,** Having access to usefu real-time information for your holiday, traffic, parking, etc.
- + **Entertainment for the whole family** (TV series, movies, cartoons and your favourite games online)
- + **Stay in touch** Having the ability to check emails and messages.
- + **Sharing holiday experiences**



## Wi-Fi COMBINED WITH SMART TV

THE CONNECTION  
AMPLIFIES YOUR  
RELAXATION!



32" ULTRA WIDESCREEEN

12 V/230 V POWER SUPPLY

*Optional equipment.*



**YOUR PREFERRED STREAMING CHANNELS**  
on a large screen, on holiday.

**YOUR FAVOURITE APPS**  
within remote control reach, surfing and viewing  
them on a large screen.

**INFORMATION ABOUT YOUR DESTINATION,**  
directly available on a large screen.

**YOUR DEVICES AVAILABLE,**  
while saving battery, preserving it for any other use.

LET'S COMBINE THE Wi-Fi CONNECTION WITH A SMART TV!  
A DEDICATED PACK IS NOW AVAILABLE.



**NATURAL LIGHT.**

Correct interior lighting as an essential element of living comfort.

Front skydome.

5 windows.

2 windows in the driver's cab.  
Entrance door window.

3 portlights 40x40 cm.

1 rear portlight 70x50 cm.

**TECHNOLOGY AND COMFORT**



## LIGHTING.

Unique and stylish lighting that can furnish as well as provide light for your favourite activities.

100% LED.  
Sustainable.  
Environmentally friendly.  
Long-lasting.  
Greater autonomy.

**Main lights: 4 dome lamps.**  
**Diffused light: under-cabinet light frames and furnishing LEDs.**  
**Courtesy lights: floor step markers.**

*Technology, Design and Comfort*





## SOFT TOUCH COATING

A SOFT BOUNDARY  
BETWEEN THE  
OUTSIDE WORLD AND  
THE INSIDE.

Insulation and protection  
In all seasons.

- + WALLS AND ROOF.**  
Wall and roof coated by  
soft-touch fabrics.  
Rear and living area.





## THE DRIVER'S CAB.

**A place to live in,  
rather than to travel!**

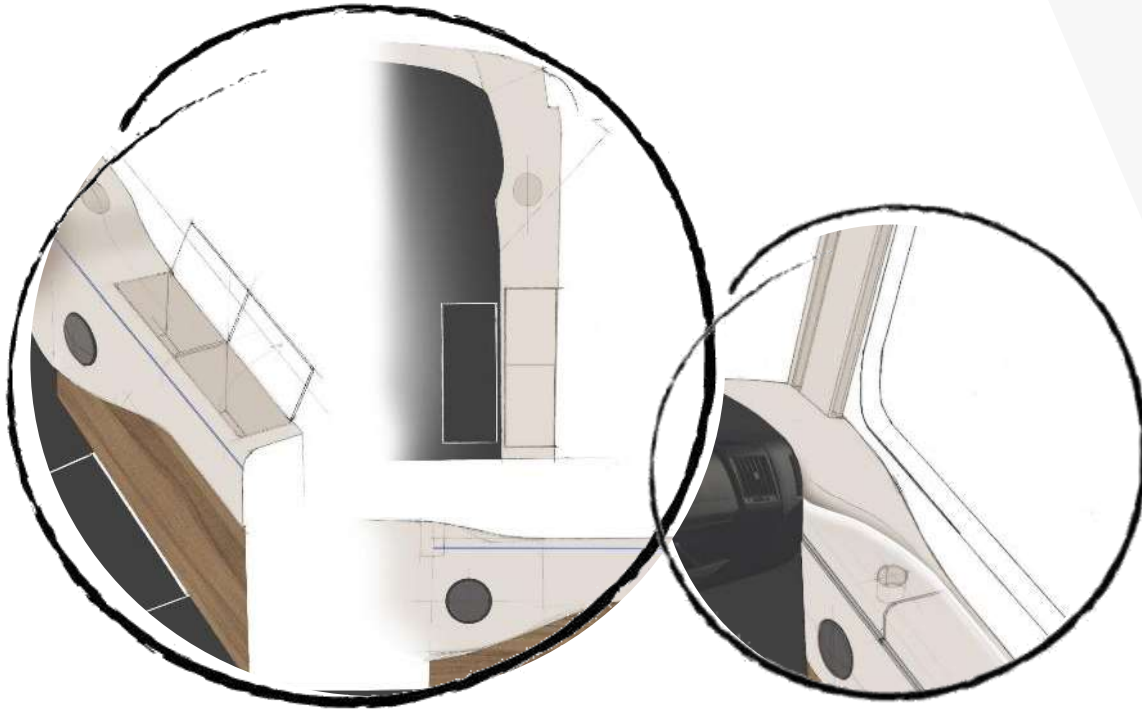

The passenger seat becomes a "relaxation seat", equipped with comfort elements and designed to integrate the cab as an extension of the living area.

- +** "Slim" design and stowage capacity
- +** Space integrated and perfectly fit with the new Fiat dashboard.
- +** Style coordinated with the interior furniture. Two colours. LED light strips.

# Pleasant living room effect.



SKYDOME.  
PORTLIGHT IN THE AISLE.



WALL UNITS UNDER  
THE ELEVATING BED.



USB SOCKETS FOR  
DEVICE CHARGING.



CHAISE LONGUE  
ARRANGED BETWEEN  
CAB SEAT AND SOFAS.



SOFT TOUCH ROOF AND FLOOR.  
ANTI-CONDENSATION  
FURNITURE AND SPACED  
DINETTE WALLS.



FOLDING TOP TABLE IN  
REAL WOOD VENEER.  
CHROME TABLE LEG



CONVERTIBLE FACE TO  
FACE DINETTE.  
EXTENDED SOFAS.  
INTERNAL STOWAGE  
COMPARTMENT.



FLOOR HATCH

## KITCHEN.



### Ergonomics and functionality

- + VALUE AND FUNCTIONALITY: BEAUTIFUL, EASY TO CLEAN AND DURABLE.**  
Acrylic stone top moulded in a continuous surface, in a one-piece mould with integrated sink. Acrylic stone is a durable material that is easy to maintain.
- + MODULAR AND EXTENSIBLE SPACES.**  
Expandable surface. The "bridge" chopping board expands and modulates the surface as needed.
- + EXTRA SURFACE AREA. WIDE TOP ALSO WITH BURNERS IN USE. COMPLETE AND FULL OF ACCESSORIES.**  
Multifunctional chopping board.  
Practical basins and integrated storage compartments.
- + PLENTY OF SPACE.**  
1 sliding large drawer.  
1 basket.  
2 drawers.  
1 fitted door.

*Chef in less than one metre.*

ACRYLIC STONE TOP  
WITH MULTIFUNCTIONAL  
AND MULTISPACE  
SINK COVER.



STOWAGE.  
1 SLIDING LARGE DRAWER.  
1 LOWER BASKET  
UNDER THE PENINSULA.  
2 DRAWERS.  
1 FITTED DOOR.



MODULAR AND  
EXTENSIBLE  
SPACES.

INTEGRATED STORAGE  
TRAYS IN TWO  
DIFFERENT SIZES.  
WITH COVER.



**SINK COVER  
IN TWO PARTS.**

**The sink cover that multiplies your space!**

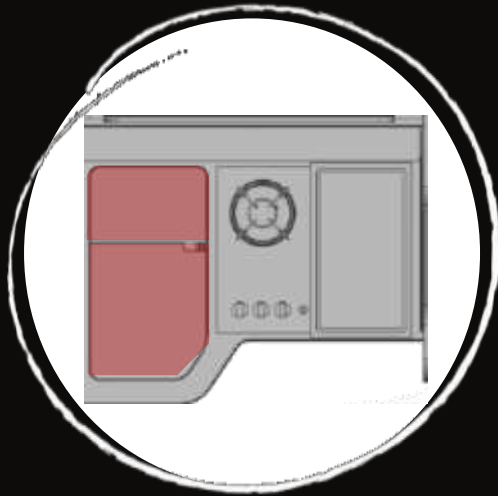

**ALL SURFACE.**

The sink cover protects the sink and offers a truly remarkable workspace.

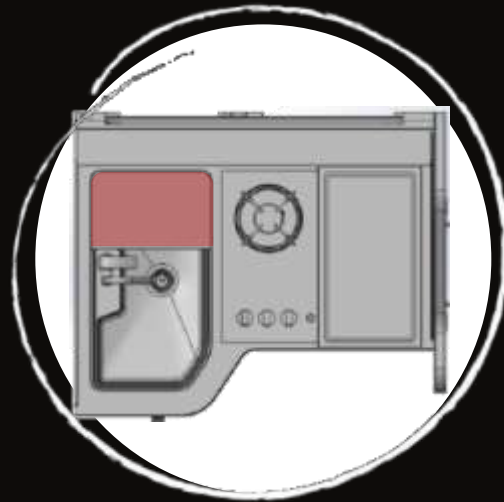

**LARGE BASIN.**

A "wide" sink to use, a "supporting" countertop

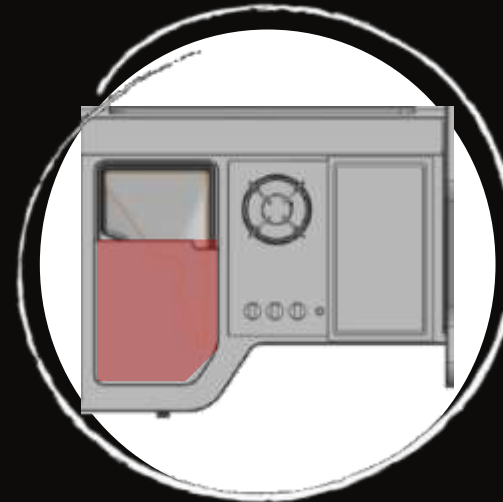

**SMALL BASIN.**

A "supporting" sink, a "wide" countertop.

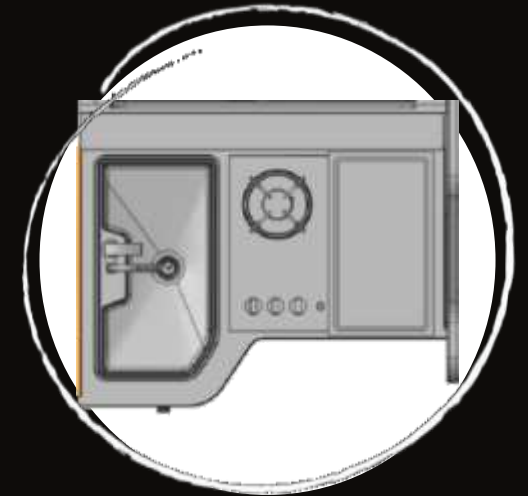

**ALL SINK!**

An extra capacity sink for kitchen activities.

**"BRIDGE"  
CHOPPING BOARD.**

**The chopping board that multiplies the surface area!**

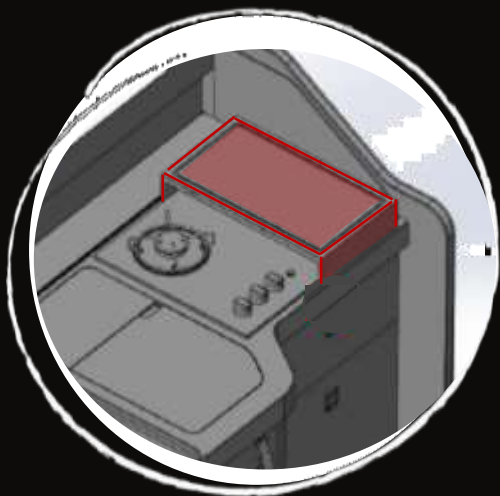

**FOR SHORT  
BREAKS ONBOARD  
THE MOTORHOME.**

Cook with just one burner and use the side countertop.

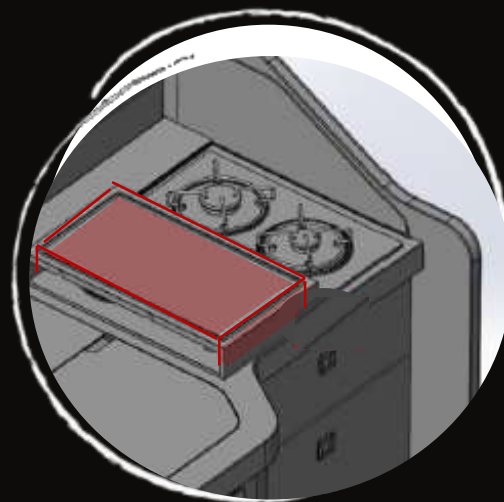

**TWO CONVENIENT  
BURNERS.**

For the daily preparation of your meals.

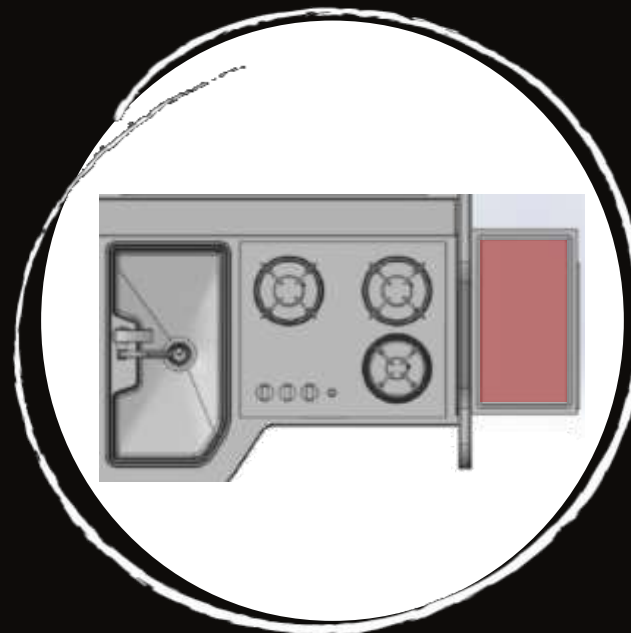

**FOR THE CHEF IN THE  
MOTORHOME...**

Three burners are on hand. And an additional countertop.

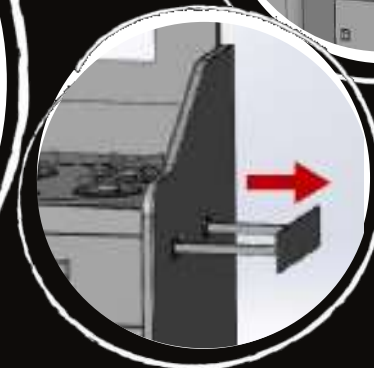

**...WITH LOTS OF  
EXTRA SURFACE.**

Quick extension of the top thanks to the handy retractable bracket.

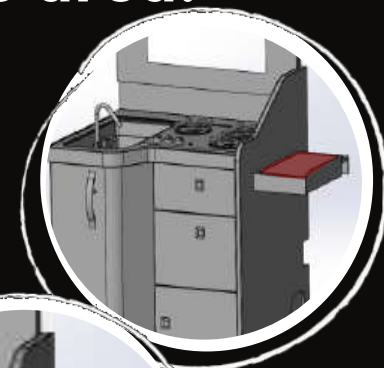

## TOILET.

A SPA in your motorhome.



- + MOVE FREELY.**  
Increased shower dimensions.  
Rain shower head for a unique experience (with the option of a practical handheld shower sprayer).
- + LIVEABLE SPACE.**  
Wooden shower platform.  
It increases the liveable space to move freely on a linear surface.  
The space can also be used after showering (water remains under the platform).
- + APPEAL AND SUBSTANCE.**  
Toilet with wooden interior, in teak wood colour laminate and matt, antibacterial laminate top.  
Reinforced ABS shower base.  
Shower with 2 drain holes.
- + IN A SMALL SPACE, YOU HAVE EVERYTHING. OPTIMIZED SPACE.**  
Large storage caddy.  
Wall mirror and on wall unit.  
Large washbasin.
- + VARIABLE VOLUMES FOR COMPACT VEHICLES.**  
Modular bathroom for model 64.



**GRAVITY SHOWER HEAD.**



**INCREASED DIMENSIONS.**

**Model 64**  
Height 1.960 mm  
Dimensions 800x710 mm

**Model 86**  
Height 1.940 mm  
Dimensions 720x700 mm

**Model 90**  
Height 1.940 mm  
Dimensions 720x650 mm



**POSSIBILITY OF A PRACTICAL SHOWER SPRAYER. LARGE STORAGE CADDY.**



**REINFORCED ABS SHOWER BASE. SHOWER WITH 2 DRAIN HOLES. WOODEN SHOWER PLATFORM.**



**SKYLIGHT 40x40 cm**



**STORAGE.**



**WALL MIRROR**



**LARGE WASHBASIN.**



## REINFORCED SHOWER BASE

**Abs thermoforming.  
Reinforced with polyurethane  
foam.**

**High-density foam for  
More rigidity and resistance**

**No strains.  
No cracks.  
No crimps.**

*Technique*





FIXED BEDS.  
IMPROVED INSULATION.  
NO BAD SMELLS FROM THE GARAGE.

SOFT TOUCH WALLS  
AND CEILING.



ROMAN BLINDS.  
ECO-LEATHER PANELS.  
GLOSSY LAMINATES.



DOUBLE DRAWER.



EXTRA LARGE WINDOWS  
AND SKYLIGHTS.  
FLYSCREEN AND BLIND.

AUDIO SPEAKERS TO  
RELAX WITH MUSIC.



SLATTED BASES,  
ERGONOMIC MATTRESSES.



TWO  
DRAWERS.



WARDROBE.



WARDROBE.

## BED TYPE OFFER

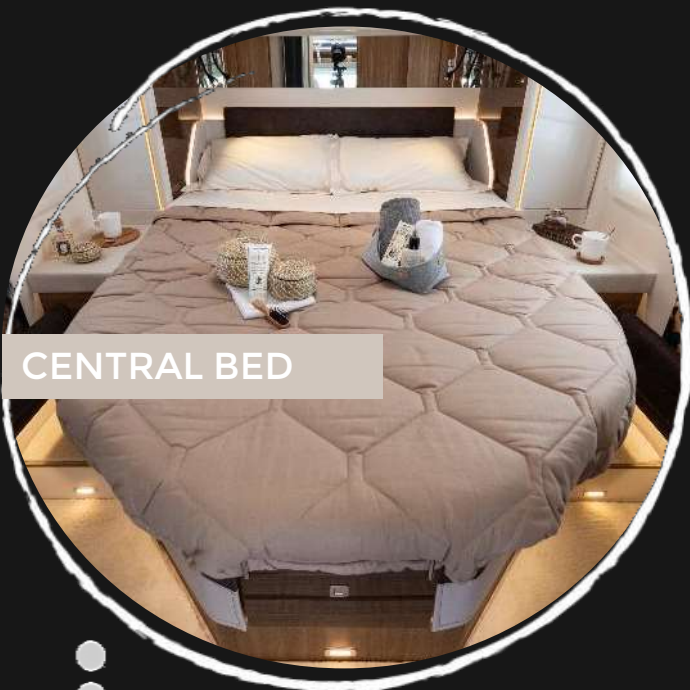

CENTRAL BED

Central bed, 194x150 cm.  
Ground clearance,  
first step: 19 cm.  
With slatted base with zippers.  
Stowage under the bed, access from  
the base lifted through pistons.  
Exterior pockets and panels.

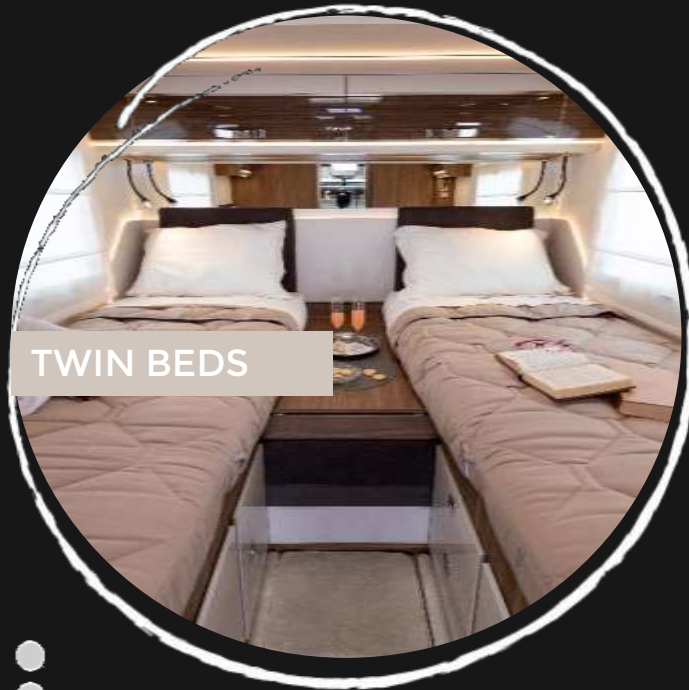

TWIN BEDS

Right bed 199x83 cm.  
Left bed 203x84 cm.  
Possibility to join in a single double bed  
217x200 cm.  
Two drawers.  
Accessible with full base piston lifting.  
Right, door, with 3 shelves,  
Left. Door, with rod.  
Steps with stowage.

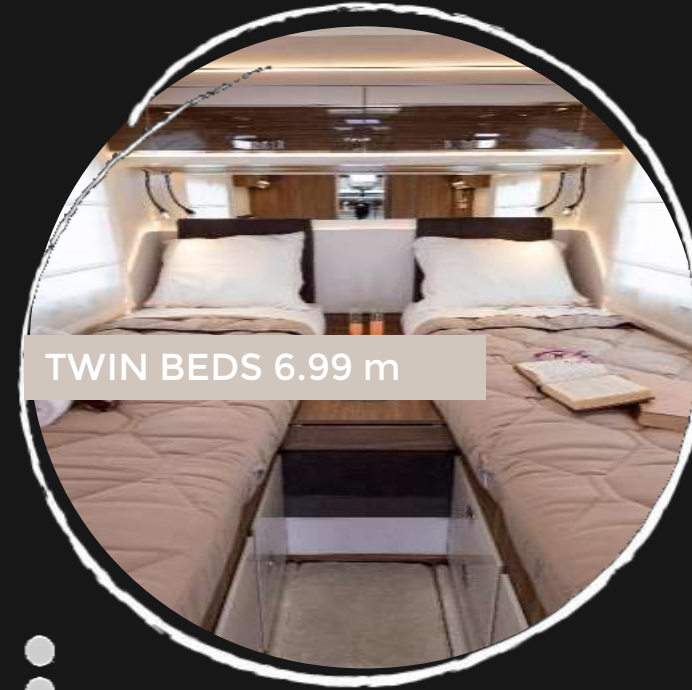

TWIN BEDS 6.99 m

Right bed 195x83 cm.  
Left bed 191x83 cm.  
Possibility to join in a single double bed  
217x192 cm.  
Two drawers.  
Accessible with full base piston lifting.  
Right, door, with 3 shelves,  
Left. Door, with rod.  
Steps with stowage.

# RANGE PLAN 2022

> 6 METRES ●●●●●● > 7 METRES

< 7.5 METRES ●●●

K-YACHT  
TEKNO LINE



K-YACHT TEKNO LINE 64



K-YACHT TEKNO LINE 86



K-YACHT TEKNO LINE 90

MOTORHOME

# K-YACHT TEKNO LINE 64

**GARAGE:**  
RIGHT DOOR 112x87(72) cm  
LEFT DOOR 112x87(72) cm

**THREE-WAY  
REFRIGERATOR,  
145 l**

**FACE TO FACE  
DINETTE**

➔ **6.99 m**

**WHEEL-BASE 3800 mm**

1928 mm 555 mm 905 mm 1175 mm

2350 mm

**ADDITIONAL  
MATTRESS FOR  
REAR BEDS**



1928 mm 1070 mm 782 mm 783 mm

**SLEEPING/LIVING  
AREA RIGID  
PARTITION DOOR**

**NEW  
VARIABLE  
SPACE TOILET**

**XL DOOR**

**FOLDING TOP TABLE**  
Folded 74x40 cm  
Unfolded 74x80 cm.

## BED DIMENSIONS

REAR BED 195x83-191x83 cm

DINETTE BED 216x100 cm

MOTORHOME CAB BED

190x145 cm



**EURO 6-d**

**2.2 MULTIJET - 140 HP**

**APPROVED SEATS 4**

**SLEEPS 4**

## PORTLIGHT

REAR	70 x 50
AISLE	
DINETTE	70 x 50
TOILET	40 x 40
SHOWER	-
SKYDOME	STD 100x80 cm

**TRUMA COMBI 6 kW  
Heating  
CP PLUS CONTROL**



# K-YACHT TEKNO LINE 86



EURO 6-d

2.2 MULTIJET - 140 HP

APPROVED SEATS 4

SLEEPS 4

## PORTLIGHT

REAR	70 x 50
AISLE	
DINETTE	70 x 50
TOILET	40 x 40
SHOWER	-
SKYDOME	STD 100x80 cm

TRUMA COMBI 6 kW  
Heating  
CP PLUS CONTROL



GARAGE:  
RIGHT DOOR 112x87(72) cm  
LEFT DOOR 112x87(72) cm

SEPARATE  
TOILET  
INDEPENDENT  
SHOWER

FACE TO FACE  
DINETTE

7.51 m

WHEEL-BASE 4035 mm

2071 mm

997 mm

905 mm

1168 mm

2350 mm

ADDITIONAL  
MATTRESS FOR  
REAR BEDS

2023 mm

624 mm

555 mm

790 mm

1101 mm

SLEEPING/LIVING  
AREA RIGID  
PARTITION DOOR

THREE-WAY  
REFRIGERATOR,  
145 l

**XL DOOR**

FOLDING TOP TABLE  
Folded 74x40 cm  
Unfolded 74x80 cm.

## BED DIMENSIONS

REAR BED 199x83-203x84 cm

DINETTE BED 216x100 cm

MOTORHOME CAB BED

190x145 cm

# K-YACHT TEKNO LINE 90

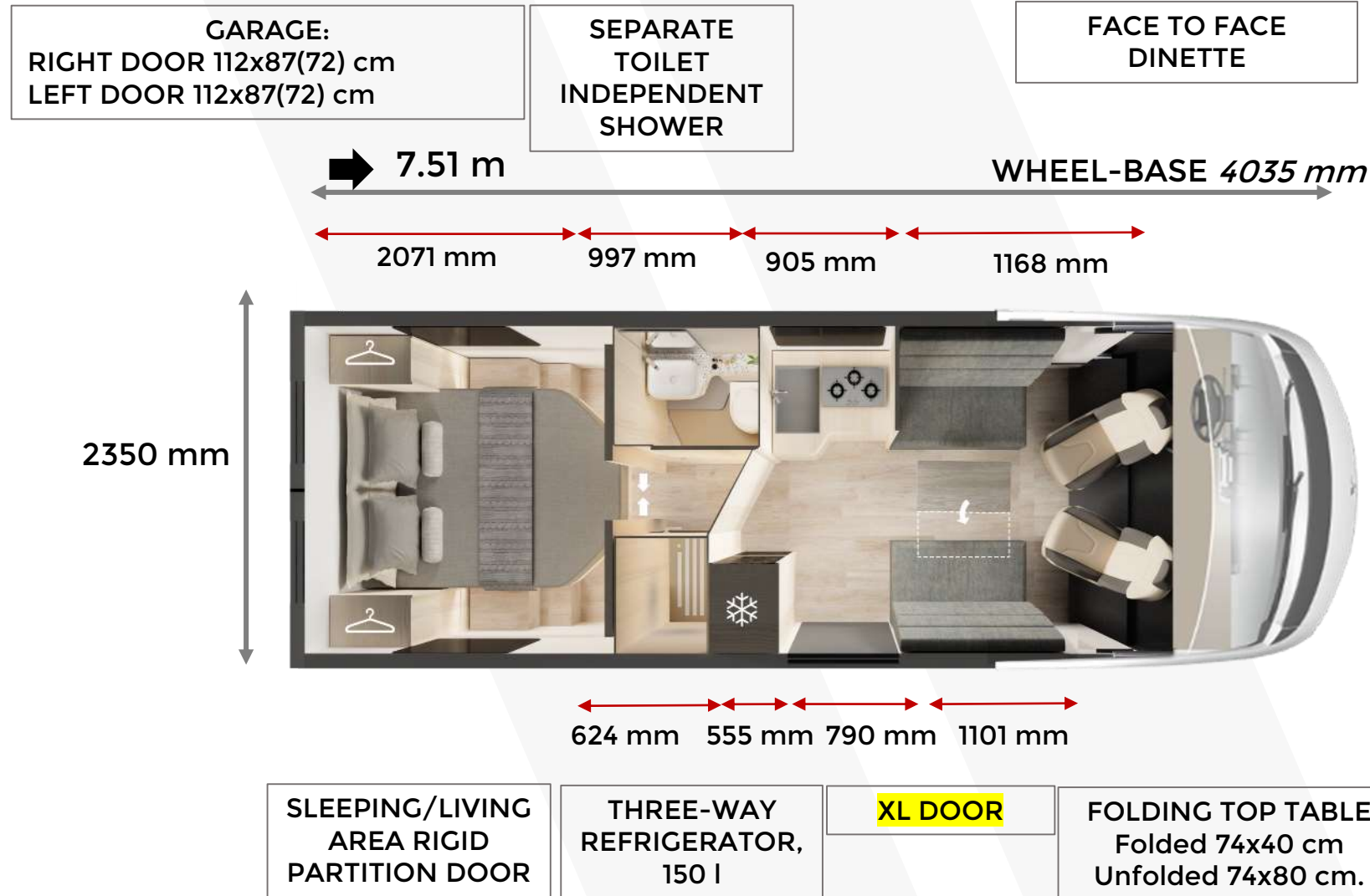

EURO 6-d

2.2 MULTIJET - 140 HP

APPROVED SEATS 4

SLEEPS 4

## PORTLIGHT

REAR 70 x 50

aisle

DINETTE 70x50

TOILET 40 x 40

SKYDOME STD 100x80 cm

## BED DIMENSIONS

REAR BED	194x150 cm
DINETTE BED	216x100 cm

MOTORHOME CAB BED	190x145 cm
-------------------	------------

TRUMA COMBI 6 kW  
Heating  
CP PLUS CONTROL



# SLEEPING/LIVING AREA PARTITION



**+**  
OPEN SPACE  
WALKABLE SPACE  
EASY PASSAGE

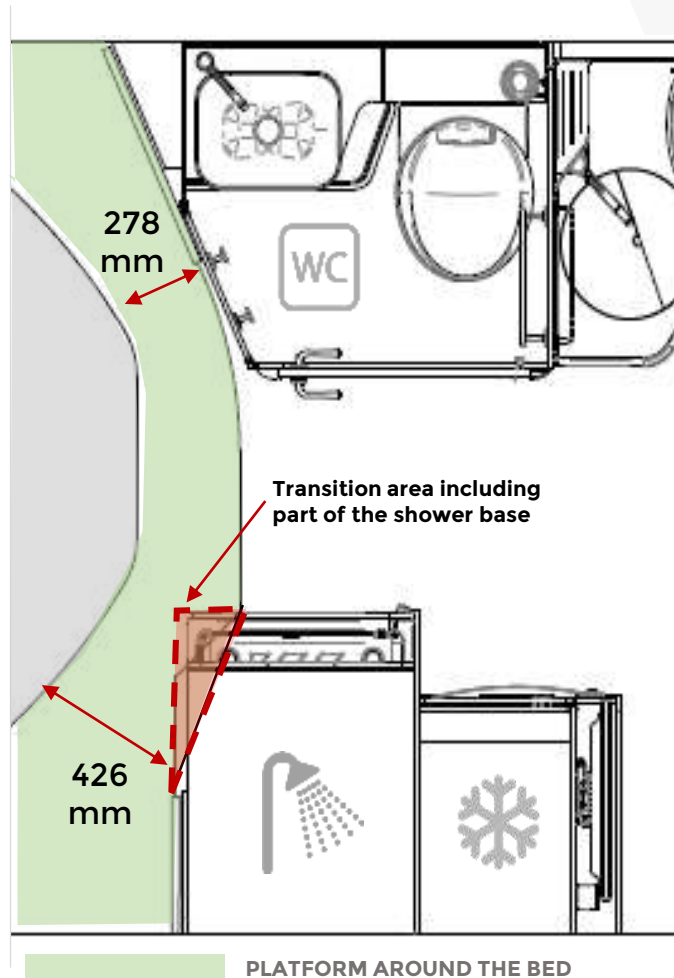

PLATFORM AROUND THE BED

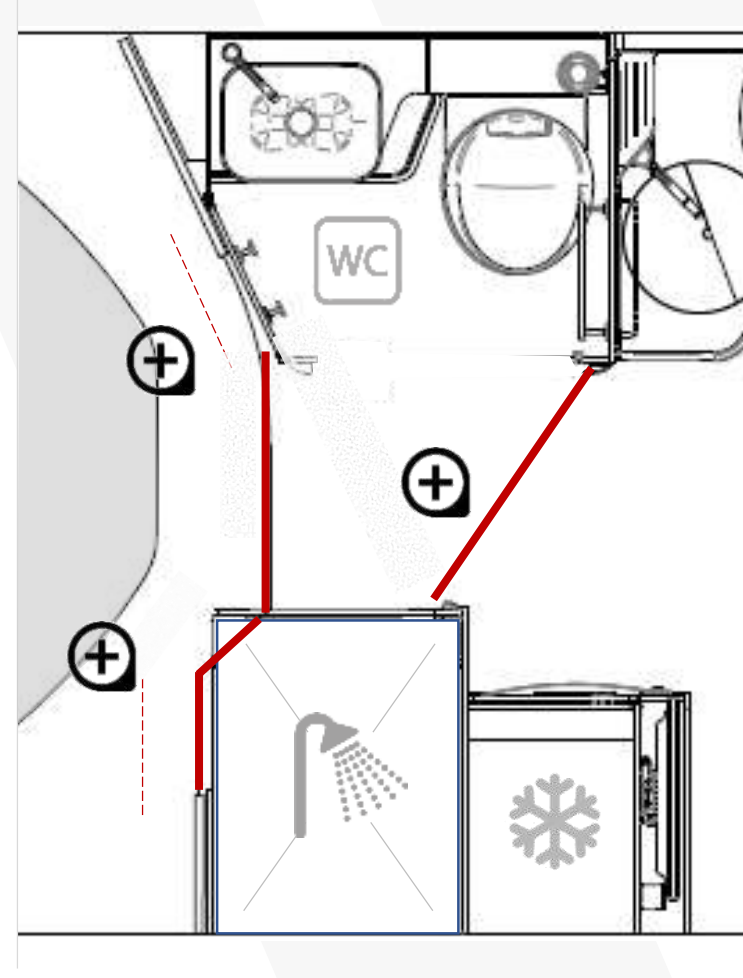

- +** SLIDING DOOR  
rigid to close  
the room.
- +** SLIDING DOOR  
Double with  
fixed part and  
hinged end.
- +** TOILET DOOR  
Hinged for space  
in toilet or  
dressing area.



# K-YACHT TEKNO LINE RANGE, EQUIPMENT



## CHASSIS

POWER UNIT	140 HP
AL-KO CHASSIS	STANDARD
MANUAL AIR CLIMATE CONTROL SYSTEM	STANDARD
DRIVER + PASSENGER AIR BAG	STANDARD
TRACTION +/- HILL DESCENT	STANDARD
CRUISE CONTROL	STANDARD
16" ALLOY WHEEL RIMS COMPOSITE SUSPENSION	STANDARD
LED DRLs	STANDARD
STEERING WHEEL CONTROLS	STANDARD
BUS-TYPE REAR-VIEW MIRRORS	STANDARD

## LIVING UNIT

REFRIGERATOR	145 l
KITCHEN TOP	3 BURNERS
BATHROOM/SLEEPING AREA WOODEN PARTITION DOORS	STANDARD
PLEATED BLIND	STANDARD
LIVING UNIT SPEAKERS	STANDARD
FLOOR HATCH	STANDARD
TV HOLDER WITH EXTENSIBLE ARM	STANDARD
CONNECTION READY FOR WI-FI	STANDARD
REINFORCED ABS SHOWER BASE + PLATFORM	STANDARD
HEATER	TRUMA COMBI 6
CP PLUS CONTROL	STANDARD
SOFT TOUCH WALLS AND ROOF (kitchen and toilet excluded)	STANDARD
FOLDING TOP TABLE	STANDARD
CHaise LONGUE PASSENGER SEAT	STANDARD
TWIN BEDS EXTENSION (64, 86)	STANDARD

## EXTERIORS

2-PART XL DOOR + WINDOW	STANDARD
LIVING UNIT DOOR FLYSCREEN	STANDARD
CENTRAL LOCKING	STANDARD
EXTERIOR LIGHT	STANDARD
SKY DOME	STANDARD
REAR BED PORTLIGHT	70 x 50
ALUMINIUM BANDS	STANDARD
ABS REAR COLUMNS LED HEADLIGHTS	STANDARD
HEATED TANK	STANDARD
OVERSIZED TANKS (clear/grey water)	145/135 litres
INTEGRATED AND INSULATED STEP	STANDARD
OPENABLE BAND WITH MAXI-GARAGE	STANDARD
EXTERNAL GAS SOCKET, EXTERNAL WATER SOCKET, EXTERNAL ELECTRIC SOCKET AND TV SOCKET	STANDARD

# UPHOLSTERY



**PRESTIGE**  
Standard,  
Imitation leather



**PRESTIGE BROWN**  
Optional,  
Imitation leather and fabrics

**KROSSER RANGE.**  
***NEW FOR 2022***

# RANGE PLAN 2022

> 6 METRES ●●●●●● > 7 METRES

< 7.5 METRES ●●●

KROSSER



KROSSER 64



KROSSER 70



KROSSER 86



KROSSER 90

HALF-INTEGRATED

# KROSSER 64

**GARAGE:**  
RIGHT DOOR 130x87 (72) cm  
LEFT DOOR 130x87 (72) cm

**THREE-WAY  
REFRIGERATOR,  
145 l**

**FACE TO FACE  
DINETTE**

➔ 6.99 m

WHEEL-BASE 3800 mm

1928 mm 541 mm 935 mm 1014 mm

2350 mm

**ADDITIONAL  
MATTRESS FOR  
REAR BEDS**



1928 mm 1058 mm 803 mm 643 mm

**SLEEPING/LIVING  
AREA RIGID  
PARTITION DOOR**

**NEW  
VARIABLE  
SPACE TOILET**

**XL DOOR**

**FOLDING TOP TABLE**  
Folded 74x40 cm  
Unfolded 74x80 cm.

## BED DIMENSIONS

REAR BED 189x80-189x80 cm

DINETTE BED 216x98 (63) cm

ELEVATING BED (OPTIONAL)

190 x 128(107) cm



EURO 6-d

2.2 MULTIJET - 140 HP

APPROVED SEATS 4

SLEEPS 4

## PORTLIGHT

REAR	70 x 50
AISLE	40x40
DINETTE	70x50
TOILET	40 x 40
SHOWER	-
SKYDOME	STD 100x80 cm

**TRUMA COMBI 6 kW  
Heating  
CP PLUS CONTROL**



# KROSSER RANGE, EQUIPMENT



## CHASSIS

POWER UNIT	140 HP
MANUAL AIR CLIMATE CONTROL SYSTEM	STANDARD
DRIVER + PASSENGER AIR BAG	STANDARD
TRACTION +/- HILL DESCENT	 STANDARD
CRUISE CONTROL	STANDARD
16" ALLOY WHEEL RIMS COMPOSITE SUSPENSION	STANDARD
BLACK RADIATOR GRILLE + SKID PLATE AND HEADLIGHTS	STANDARD
WHITE BUMPER	STANDARD
DAB AERIAL	STANDARD
STEERING WHEEL CONTROLS	STANDARD





## LIVING UNIT

REFRIGERATOR	145 l
KITCHEN TOP	3 BURNERS
BATHROOM/SLEEPING AREA WOODEN PARTITION DOORS	STANDARD
PLEATED BLIND	 STANDARD
LIVING UNIT SPEAKERS	STANDARD
FLOOR HATCH	STANDARD
TV HOLDER WITH EXTENSIBLE ARM	STANDARD
SLEEPING AREA MAXI WINDOWS	STANDARD
REINFORCED ABS SHOWER BASE + PLATFORM	STANDARD
HEATER	TRUMA COMBI 6
CP PLUS CONTROL	STANDARD
SOFT TOUCH ROOF	STANDARD
FOLDING TOP TABLE	STANDARD
TWIN BEDS EXTENSION (64, 86)	STANDARD



## EXTERIORS

2-PART XL DOOR + WINDOW	STANDARD
LIVING UNIT DOOR FLYSCREEN	STANDARD
CENTRAL LOCKING	STANDARD
EXTERIOR LIGHT	STANDARD
SKY DOME (P VERSION)	STANDARD
REAR BED PORTLIGHT	70 x 50
REAR BANDS AND COLUMNS	ABS
HEATED TANK	STANDARD
OVERSIZED TANKS (clear/grey water)	 145/135 litres
INTEGRATED AND INSULATED STEP	 STANDARD
OPENABLE BAND WITH MAXI-GARAGE	STANDARD
GARAGE LIGHTING	STANDARD
220 V GARAGE SOCKET	STANDARD





**KEA RANGE.**  
***NEW FOR 2022***

# RANGE PLAN 2022





> 6 METRES ●●●●●● > 7 METRES

< 7.5 METRES ●●●

KEA I

 KEA i64	 KEA i67	 KEA i71	 KEA i86	 KEA i90
--	--	--	--	--

KEA P

 KEA P64	 KEA P67	 KEA P71	 KEA i86	 KEA i90
--	--	--	--	--

MOTORHOME

SEMI-MOTORHOME



# KEA P64



EURO 6-d

2.2 MULTIJET - 140 HP

APPROVED SEATS 4

SLEEPS 4

## PORTLIGHT

REAR	70 x 50
AISLE	40x40
DINETTE	70x50
TOILET	40 x 40
SHOWER	-
SKYDOME	STD 100x80 cm

TRUMA COMBI 6 kW  
Heating  
CP PLUS CONTROL

# KEA 164



GARAGE:  
RIGHT DOOR 117x87(72) cm  
LEFT DOOR 117x87(72) cm

THREE-WAY  
REFRIGERATOR,  
145 l

FACE TO FACE  
DINETTE

6.99 m WHEEL-BASE 3800 mm

1982 mm 541 mm 935 mm 1014 mm



2350 mm

ADDITIONAL  
MATTRESS FOR  
REAR BEDS

1928 mm 1058 mm 803 mm 643 mm

SLEEPING/LIVING  
AREA RIGID  
PARTITION DOOR

NEW  
VARIABLE  
SPACE TOILET

XL DOOR

FOLDING TOP TABLE  
Folded 74x40 cm  
Unfolded 74x80 cm.

## BED DIMENSIONS

REAR BED 189x80-189x80 cm

ELEVATING BED (OPTIONAL)

190 x 128(107) cm

DINETTE BED 216x98 (63)cm

CAB ELEVATING BED (motorhome)

135x190 cm

# KEA P71



EURO 6-d

2.2 MULTIJET - 140 HP

APPROVED SEATS 4

SLEEPS 3

## PORTLIGHT

REAR	70 x 50
AISLE	40x40
DINETTE	70x50
TOILET	40 x 40
SHOWER	28 x 28
SKYDOME	STD 100x80 cm

TRUMA COMBI 6 kW  
Heating  
CP PLUS CONTROL

# KEA I71



GARAGE:  
RIGHT DOOR 100x87(72) cm  
LEFT DOOR 100x87(72) cm

DINETTE  
FACE-TO-FACE

7.20 m

WHEEL-BASE 4035 mm

1982 mm 541 mm 935 mm 1014 mm

2350 mm

ELEVATING  
CENTRAL BED



1928 mm 1058 mm 803 mm 643 mm

COMFORTABLE  
TRANSITION TO THE  
SLEEPING AREA  
from 25 to 40 cm

SLEEPING/LIVING  
AREA RIGID  
PARTITION DOOR

XL DOOR

FOLDING TOP TABLE  
Folded 74x40 cm  
Unfolded 74x80 cm.

SLIM  
REFRIGERATOR,  
145 l

## BED DIMENSIONS

REAR BED 150x193 cm

ELEVATING BED (OPTIONAL) 190 x 128(107) cm

DINETTE BED 216x98 (75) cm

CAB ELEVATING BED (motorhome) 135x190 cm

# KEA RANGE, EQUIPMENT



## CHASSIS

POWER UNIT	140 HP
MANUAL AIR CLIMATE CONTROL SYSTEM	STANDARD
DRIVER + PASSENGER AIR BAG	STANDARD
TRACTION +/- HILL DESCENT	STANDARD
CRUISE CONTROL	STANDARD
16" ALLOY WHEEL RIMS COMPOSITE SUSPENSION	STANDARD
BLACK RADIATOR GRILLE + SKID PLATE AND HEADLIGHTS (P VERSION)	STANDARD
LED DRLs (I VERSION)	STANDARD
WHITE BUMPER (P VERSION)	STANDARD
DAB ANTENNA (P VERSION)	STANDARD
DAB AERIAL READY (VERSION I)	STANDARD
STEERING WHEEL CONTROLS	STANDARD



## LIVING UNIT

REFRIGERATOR	145 l
KITCHEN TOP	3 BURNERS
BATHROOM/SLEEPING AREA WOODEN PARTITION DOORS	STANDARD
PLEATED BLIND	STANDARD
LIVING UNIT SPEAKERS	STANDARD
FLOOR HATCH	STANDARD
TV HOLDER WITH EXTENSIBLE ARM	STANDARD
SLEEPING AREA MAXI WINDOWS	STANDARD
REINFORCED ABS SHOWER BASE + PLATFORM	STANDARD
HEATER	TRUMA COMBI 6
CP PLUS CONTROL	STANDARD
SOFT TOUCH ROOF	STANDARD
FOLDING TOP TABLE	STANDARD
TWIN BEDS EXTENSION (64, 86)	STANDARD



## EXTERIORS

2-PART XL DOOR + WINDOW	STANDARD
LIVING UNIT DOOR FLYSCREEN	STANDARD
CENTRAL LOCKING	STANDARD
EXTERIOR LIGHT	STANDARD
SKY DOME (P VERSION)	STANDARD
REAR BED PORTLIGHT	70 x 50
REAR BANDS AND COLUMNS	ABS
INSULATED AND HEATED TANK	STANDARD
OVERSIZED TANKS (clear/grey water)	 120/100 litres
GARAGE LIGHTING	STANDARD
220 V GARAGE SOCKET	STANDARD

**THE AVAILABLE PACKS.**

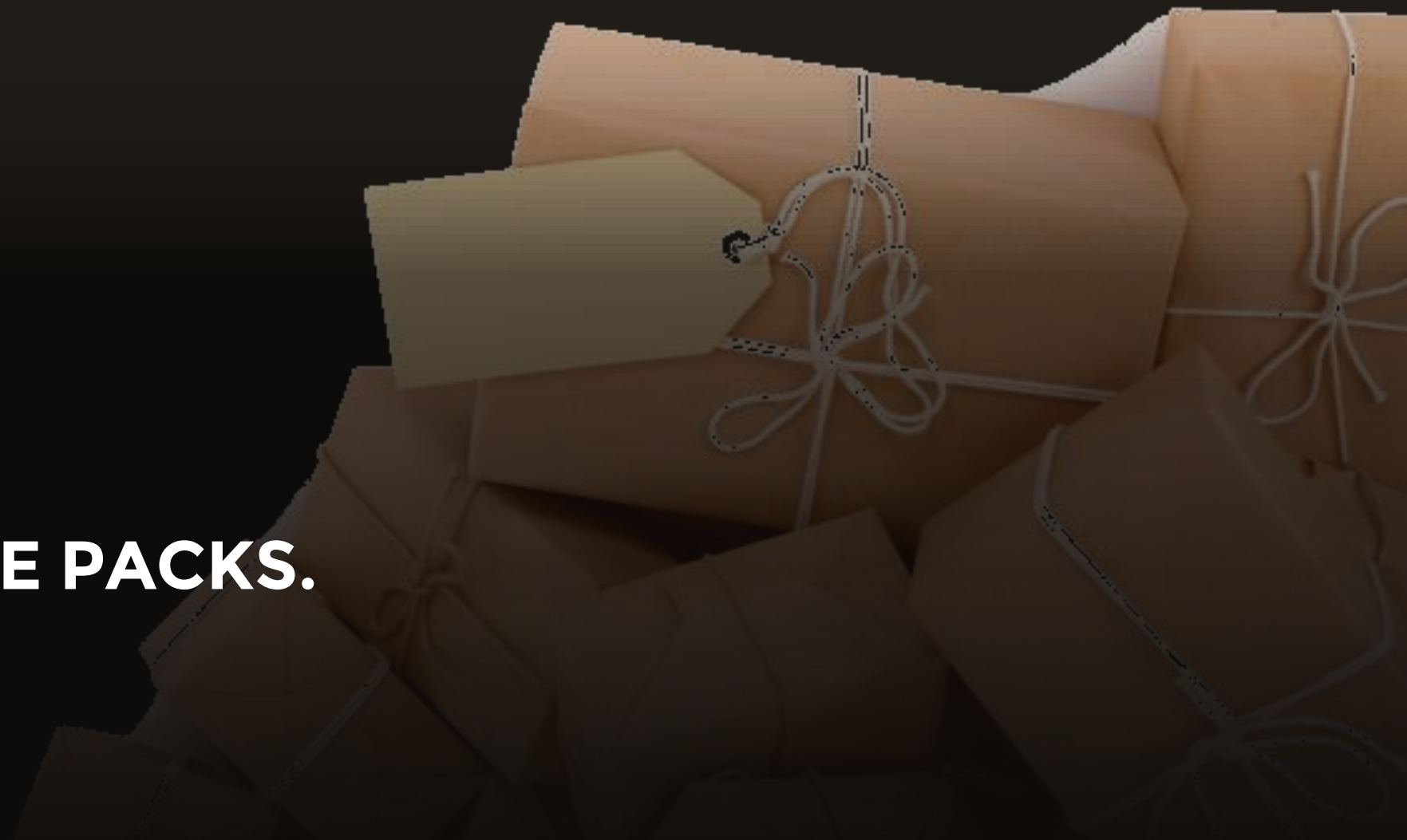

## 2022 PACKS

# Driving comfort and safety

TO INTEGRATE THE FUNCTIONALITY AND INNOVATION OF YOUR MOTORHOME.



### MATIC PACK.

Automatic transmission.

Can be matched with engines

140 HP

160 HP (with engine price delta)

180 HP (with engine price delta)



### VISION PACK.

Full LED headlights

Fog lights.



### ADVANCED SAFETY PACK.

Full brake control

Lane departure warning system

Rain and dusk sensor

Traffic sign recognition + high beam recognition

Adaptive Cruise Control

Intelligent speed assist

Driver drowsiness detection

## 2022 PACKS

# Style and comfort on board

TO INTEGRATE THE FUNCTIONALITY AND INNOVATION OF YOUR MOTORHOME.



### SPORT PACK.

DRL LED (Daytime running light)  
Leather steering wheel and gear knob  
Techno Silver dashboard  
TPMS



### ARCTIC PACK.

Truma Combi 6E  
"DuoControl" gas regulator  
Heated windscreen  
(motorhomes with cab and motorhomes)  
External covers  
Internal dashboard covers.



### EXTRA WARM PACK.

Truma Combi 6E  
"DuoControl" gas regulator  
Heated floor  
Heated windscreen  
(motorhomes with cab and motorhomes)  
External covers  
Internal dashboard covers.

## 2022 PACKS

# Technology and innovation



### DIGITAL PACK.

Full Digital Cluster  
10" Radio DAB Nav  
Wireless dashboard charging  
Double function rear-view camera  
Adjustable 120 W solar panel.



### PREMIUM PACK.

7" Radio Car Play, Android Auto  
Double function rear-view camera  
Adjustable 120 W solar panel.



### MEDIA PACK.

Wi-Fi router  
32" Smart TV (K-Yacht Tekno Line)  
24" Smart TV.

# 2022 PACKS

## Energy and autonomy

TO INTEGRATE THE FUNCTIONALITY AND INNOVATION OF YOUR MOTORHOME.

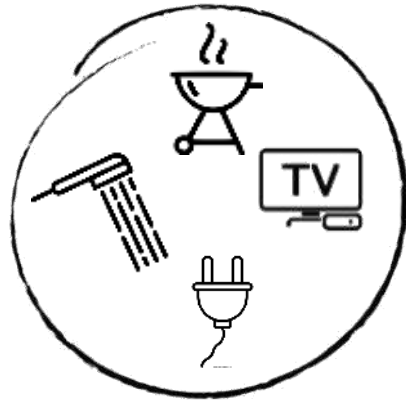

### OUTDOOR PACK.

External gas socket  
External TV socket/12 V/220 V  
External shower (inside maxi-garage).



### ENERGY PACK.

Compressor refrigerator  
Lithium battery.



# 2022 PACKS



	<i>K-Yacht Tekno Line</i>	<i>Krosser</i>	<i>Kea P</i>	<i>Kea I</i>
MATIC PACK*	X	--	X	X
DIGITAL PACK	X	X	X	X
SPORT PACK	--	X	X	--
PREMIUM PACK	X	X	X	X
ADVANCED SAFETY PACK	--	X	X	--
ARCTIC PACK	X	X	--	--
EXTRA WARM PACK	--	--	X	X
ENERGY PACK	X	X	X	X
OUTDOOR PACK	STANDARD	--	X	X
VISION PACK	X	X	X	X
MEDIA PACK 24"	--	X	X	X
MEDIA PACK 32"	X	--	--	--

Thanks

